

Personal Safety Systems

Product Catalogue

Technical Information
Component Specification



NIKO ... Quality in Motion

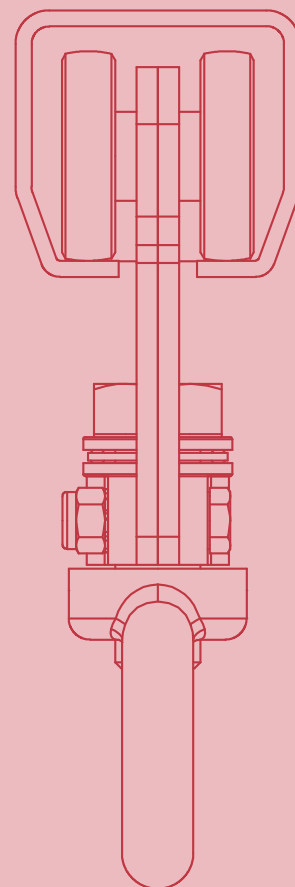

www.niko.eu.com

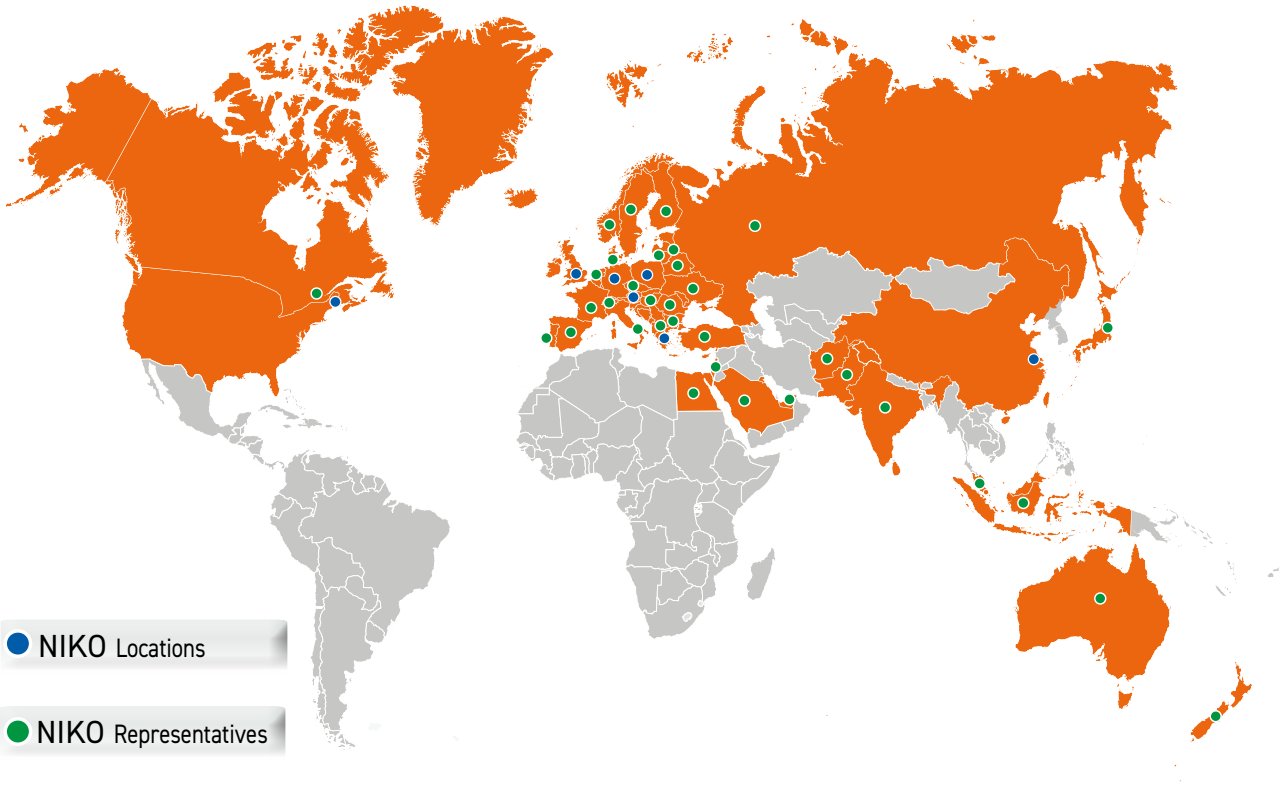

Company Profile

Established in 1972, NIKO is focused on designing, developing, producing and marketing high quality sliding door fittings and handling systems at the right price. NIKO currently has a direct presence in 7 countries and indirectly through our representatives to more than 65 countries worldwide.

Our product range includes more than 10.000 different assemblies & components making us capable of providing complete solutions to different industries worldwide. Our team of highly qualified engineers are continually working to improve our current product portfolio & extend it according to market requirements.

NIKO enforces a continuous quality control program and is certified according to ISO:9001 and ISO:14001.



Contents

Application photos	Page	4
Advantages of Niko Fall Arrest Track vs Taut Wire Systems	Page	6
Mounting points	Page	7-8
NIKO Track profiles & Track bend	Page	9-12
Support brackets & joints	Page	13-21
Track end stop	Page	21
Trolleys	Page	22
Index	Page	23-25

Application Photos

Fall Arrest System

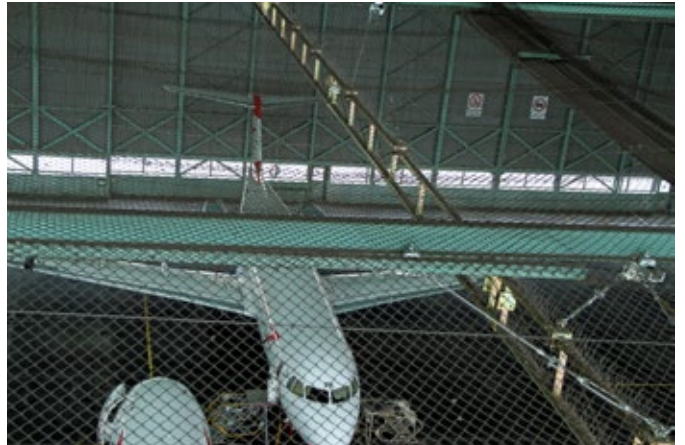

NIKO personal safety system –

The economic solution tailored to your requirements, while safety is assured

NIKO PERSONAL SAFETY SYSTEMS is a horizontal rigid track system which consists of a mobile anchorage device, allowing for a person or persons to move freely with safety in a monorail or in crane system without the need to disconnect from the system.

The small number of components required, ensure the easy installation of the system which should always be installed horizontally.

The personal safety systems NIKO PSS 25-26-27 is to be used exclusively for the safety of hanging persons. The system does not replace personal safety harnesses (PPE – personal protective equipment).

NIKO PERSONAL SAFETY SYSTEMS, consist of :

- ✓ Rigid track profiles.
- ✓ Splice joints that connect the track profiles.
- ✓ Support brackets , for wall or ceiling mounting as well as mounting to a steel structure.
- ✓ Trolleys and carriage trolleys , fitted with 4 wheels .
- ✓ Track end stops which prevent the trolley exit from the track profiles.

The components of NIKO PERSONAL SAFETY SYSTEMS comply with EN 795:2012 & CEN/TS 16415: 2013-D.

Applications

- Aircraft service and maintenance
- Safety track for high ropes course
- Coach service and maintenance
- Sky glide track for soft play areas
- Train service and maintenance

Advantages of Niko Personal Safety System vs Taut Wire Systems

- ✓ There is less distance to fall with NIKO PERSONAL SAFETY SYSTEM and therefore less impact on the body.
- ✓ No bouncing effect that can cause injury on secondary falls.
- ✓ Multiple person systems are safer with NIKO PERSONAL SAFETY SYSTEM. One person falling on a taut wire fall arrest system can cause other users to fall.
- ✓ Following a fall the NIKO PERSONAL SAFETY SYSTEM can be re-used immediately after passing a visual inspection. Taut wire fall arrest systems need to be completely replaced.
- ✓ The tapered edge design of the NIKO PERSONAL SAFETY SYSTEM achieves very free running movement and eliminates snag effect.
- ✓ Its modular design means that the NIKO PERSONAL SAFETY SYSTEMS can be easily moved, added to and changed after installation.
- ✓ NIKO PERSONAL SAFETY SYSTEM offers solutions that enable operators to pass each other without detaching themselves from the system.
- ✓ No length limits to the distance of NIKO PERSONAL SAFETY SYSTEMS.

Fall Arrest System

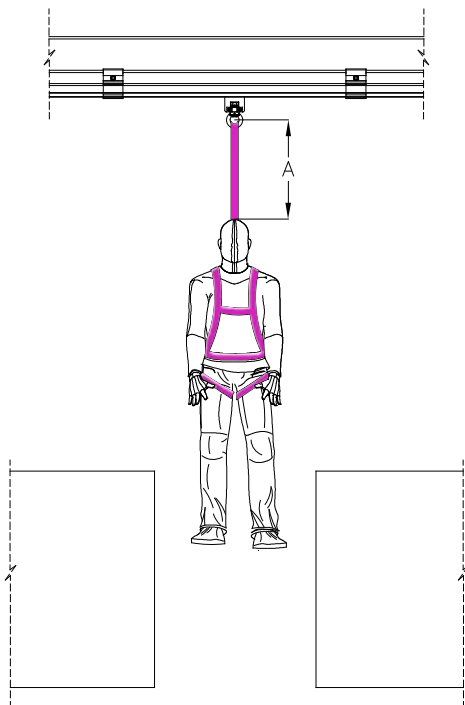

Rigid track fall arrest system

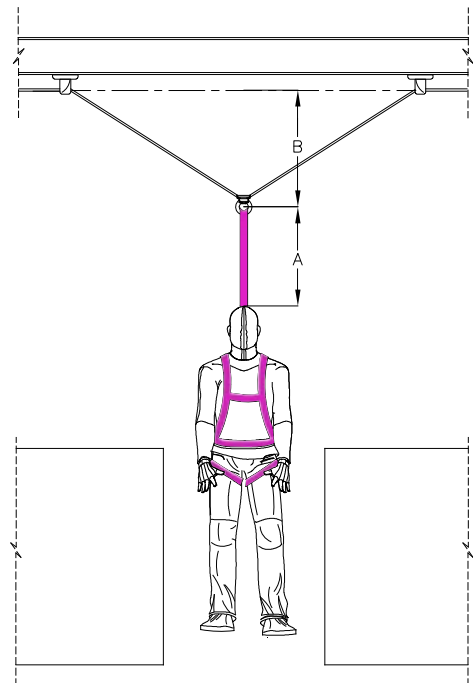

Wire rope system

A = DISTANCE REQUIRES TO ARREST
B = WIRE ROPE SYSTEM DEFLECTION

Personal Safety Systems - Mounting Points

For an effective installation of a NIKO PERSONAL SAFETY SYSTEM it is necessary to specify distance between the support brackets.

The permitted number of users in the system determines the maximum allowable distance between the support points of the track.

- a.) Determination of the maximum number of persons
- b.) Evaluation of the structural analysis of the supporting structure for the worst case scenario. In this case, all persons that are operating in the system cause at the same time a fall.
- c.) For the first person there must be calculated 12kn dynamic load effecting the system, for each additional person + 1kn.
- d.) For the maximum number of persons important is also an analysis of the rescue options.

Example of line

- A = Overhanging end max. according to chart
- B = Suspension distance max. according to chart
- C = Distance to splice joint max. 500mm
- D = Middle of bend max. 1000mm

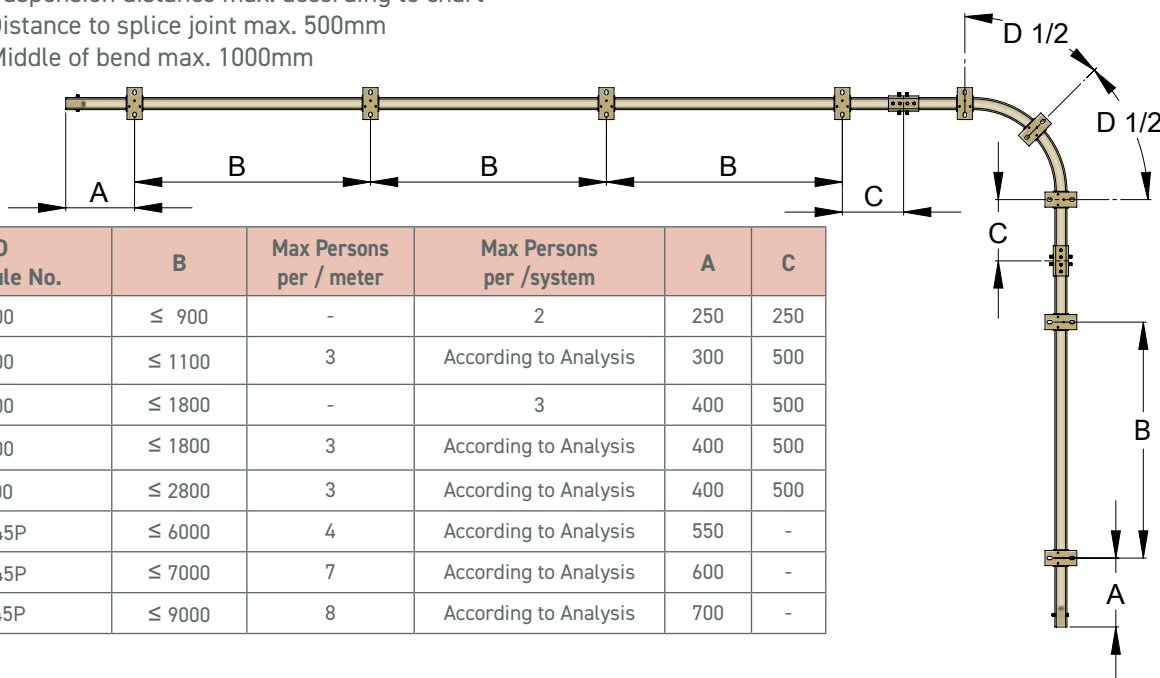

NIKO Profile No.	B	Max Persons per / meter	Max Persons per /system	A	C
24.000	≤ 900	-	2	250	250
25.000	≤ 1100	3	According to Analysis	300	500
25.000	≤ 1800	-	3	400	500
26.000	≤ 1800	3	According to Analysis	400	500
27.000	≤ 2800	3	According to Analysis	400	500
25.045P	≤ 6000	4	According to Analysis	550	-
26.045P	≤ 7000	7	According to Analysis	600	-
27.045P	≤ 9000	8	According to Analysis	700	-

Fall Arrest System

Free standing track bend personal safety system - Example

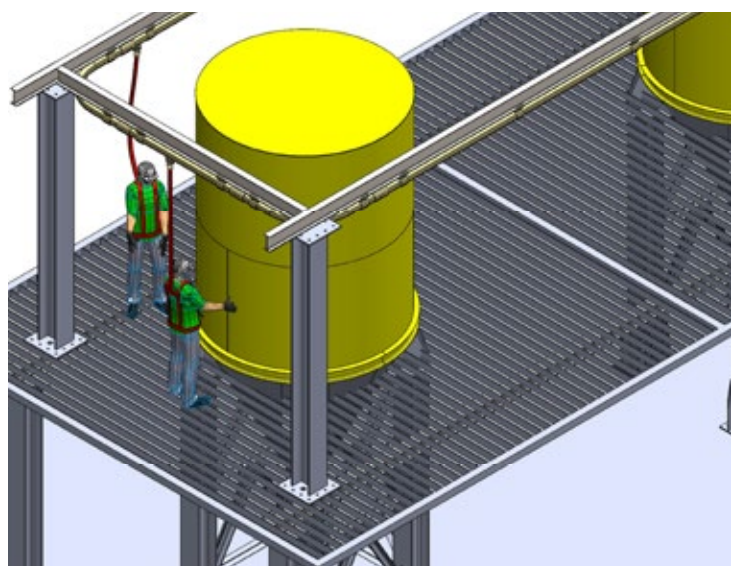

Example of line with splice joint .B30

The suspension points are indicated on the below depicted line.

The given measurements are maximum distances.

For the connection of two tracks a splice joint .B30 is used.

The distance between the splice joint and the nearest suspension point must not exceed the distance C.

A = Overhanging end max. according to chart

B = Suspension distance max. according to chart

C = Distance to splice joint .B30 max.mm

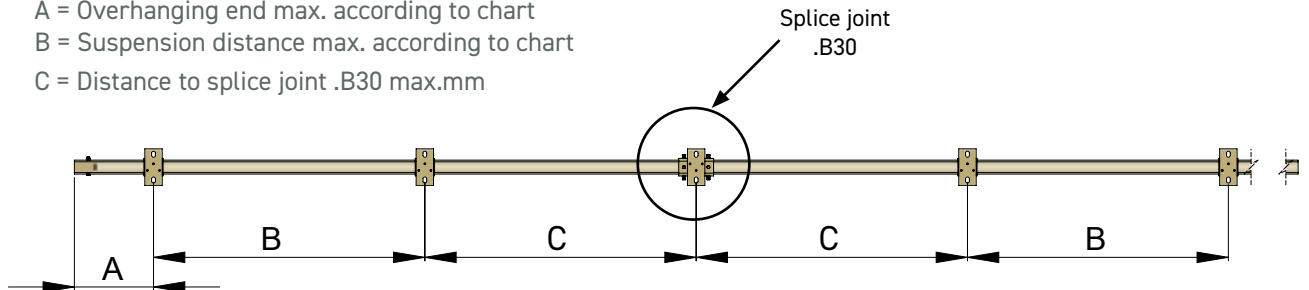

NIKO Profile No.	Suspensions/ max distances		
	B	A	C
25.000	1800	300	600
26.000	1800	400	800
27.000	2800	500	1200

Restaint Applications

NIKO Profile No.	B	Max Persons per/ Meter
25.000	≤ 1800	4
25.000	≤ 2500	2
26.000	≤ 2800	4
27.000	≤ 4000	4

Abseil Applications

NIKO Profile No.	B
25.000	≤ 1500
26.000	≤ 3000
25.045P	≤ 5000
26.045P	≤ 7000

*For monorails at 24.000 we recommend the use of splice joint with support on both side. Please advise table for mounting distances at page 7.

Monorail freestanding fall arrest system - Example



NIKO Track Profiles

Our fall arrest product range of 4 Track profile sizes can accommodate up to 3 users. For the first person there must be calculated 12kn dynamic load effecting the system, for each additional person + 1kn. The NIKO enclosed track tapered design allows correct alignment of the trolleys and reduces the possibility of dust build up. This ensures the smooth running of the trolleys and the long life of the system.

NIKO Profile No.	Dimensions			
	h (mm)	b (mm)	d (mm)	s (mm)
24.000	43,5	48,5	15	3,2
25.000	60,00	65,00	18,00	3,60
26.000	75,00	80,00	22,00	4,50
27.000	110,00	90,00	25,00	6,50

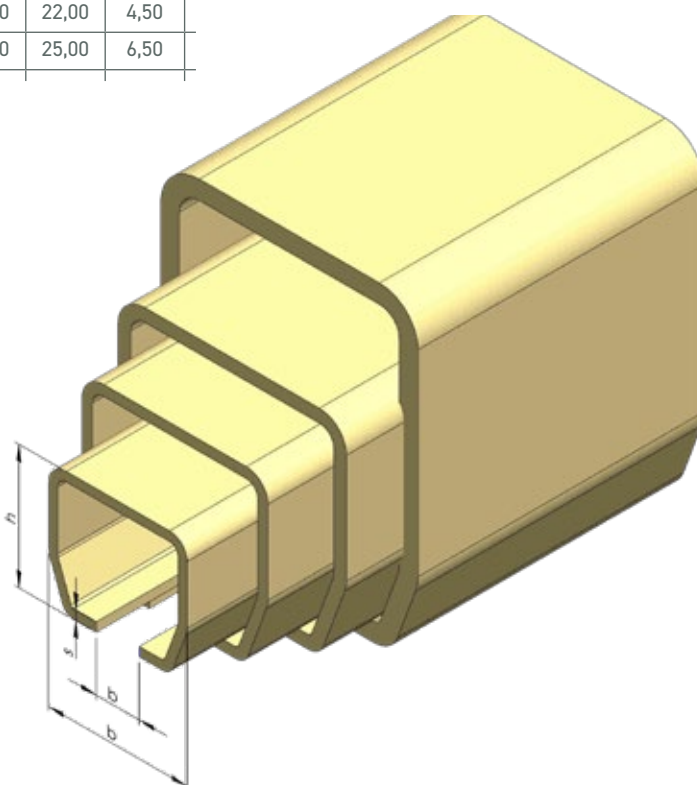
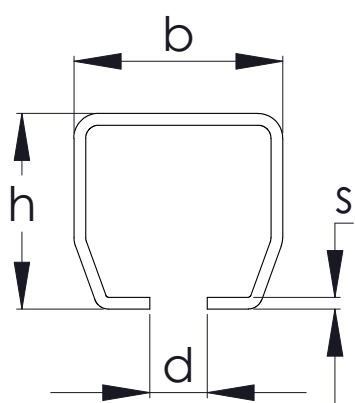

Fall Arrest System

Track bend

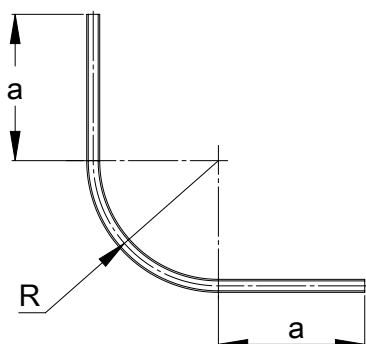

NIKO Profile No.	24.000	25.000	26.000	27.000
Track bend 90° No.	24.C06P	25.C06P	26.C08P	27.C10P
a (mm)	550 ± 20	550±20	900±20	690±20
R (mm)	580 ± 15	580±15	770±20	1035±20
L (mm)	2000	2000	3000	3000

Other bend angles available upon request.

Personal Safety Systems

We reserve the right for technical amendments without obligation.
The product pictures and drawings depicted in this catalogue do not always reflect all available sizes.

Reinforced Track profiles

Reinforced track profile with welded square profiles (25/26/27.045P).

CEN/TS16415:2013-D

This type of reinforcements are used for applications that require wide spans in a monorail or as a long travel tracks in a fall arrest crane system.

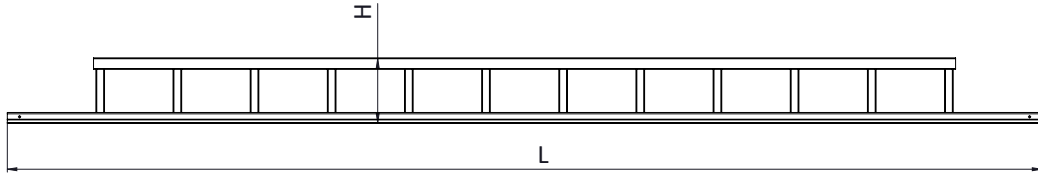

NIKO Profile No.	25.000	26.000	27.000
Part No.	25.045P	26.045P	27.045P
L max (m)	6	7	9
H (mm)	260	325	420

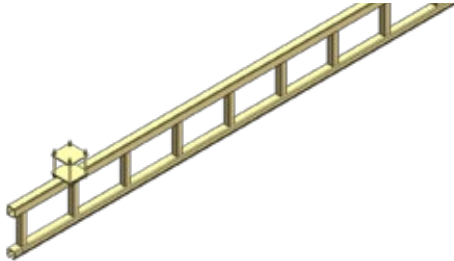
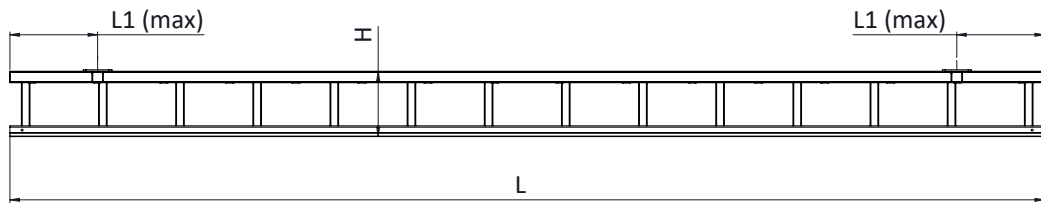

NIKO Profile No.	25.000	26.000	27.000
Part No.	25.045P	26.045P	27.045P
L max (m)	6	7	9
L1 max (mm)	550	600	700
H (mm)	260	325	420

Fall Arrest System

Light crane with reinforced tracks .045P - Example

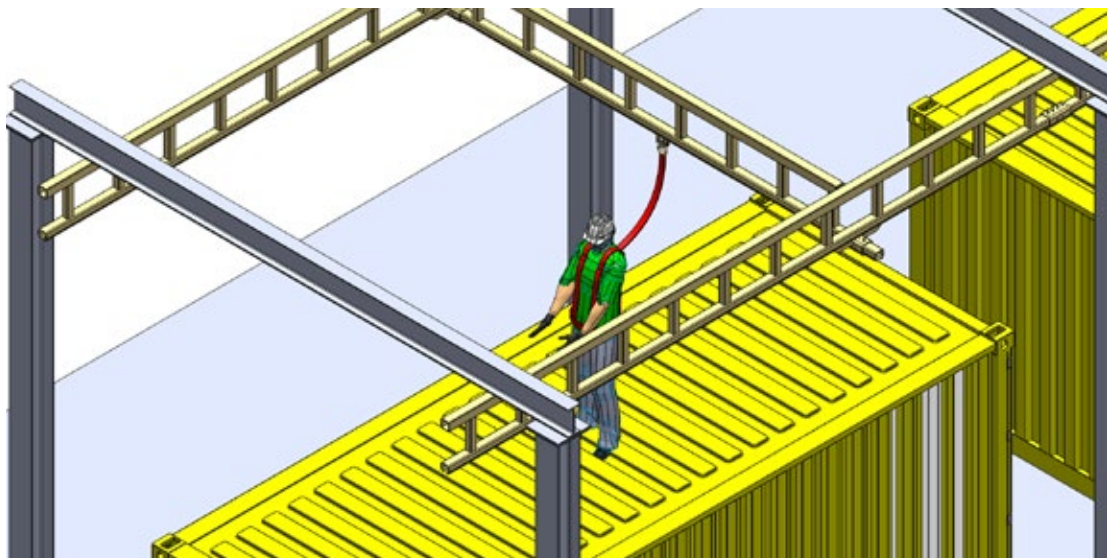

Personal Safety Systems

We reserve the right for technical amendments without obligation.
The product pictures and drawings depicted in this catalogue do not always reflect all available sizes.

Dual reinforced track profile with welded square profiles (25/26/27.048P) CEN/TS16415:2013-D

This type of reinforcements are used for monorails with wide spans, dual tracks allow two or more users to pass each other in the same working area.

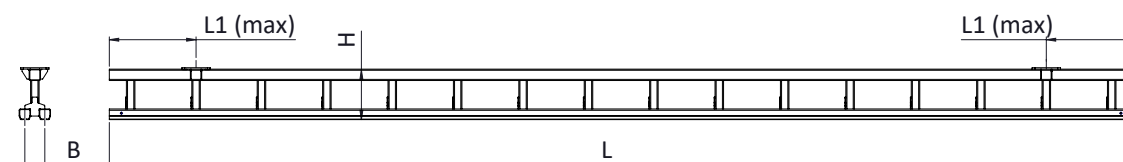

NIKO Profile No.	25.000	26.000	27.000
Part No.	25.048P	26.048P	27.048P
L max (m)	6	7	9
L1 max (mm)	550	600	700
H (mm)	260	325	420
B (mm)	115	140	170

Fall arrest application

NIKO Profil Nr.	Span (m)								
	1	2	3	4	5	6	7	8	9
	Max Persons/Meter								
24.000	2								
25.000	3								
26.000	3								
25.045P	3					2			
26.045P	7						3		
27.045P	7								
25.048P	7								
26.048P	7								
27.048P	8								

Restraint Applications

NIKO Profil Nr.	Span (m)					
	1	2	3	4	5	6
	Max Persons/Meter					
24.000	3	2				
25.000	3		2			
26.000	3			2		
27.000	3				2	

Abseil Applications

NIKO Profil Nr.	Span (m)								
	1	2	3	4	5	6	7	8	9
25.000	1,3(m)								
26.000	2,7(m)								
25.045P	4,7(m)								
26.045P	7(m)								
27.045P	9(m)								

Reinforced track .048P - Example

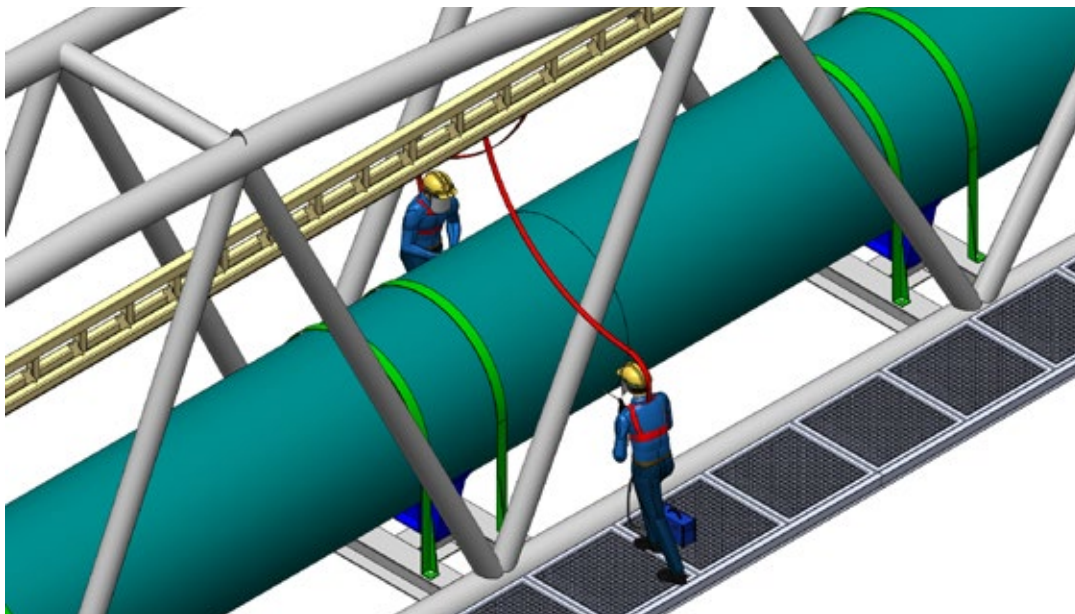

Support bracket

B00P

Zinc plated or plain, that can be used and adapted for specific applications where standard supports are unsuitable. CEN/TS16415:2013-D

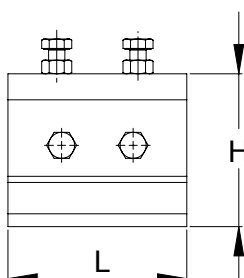
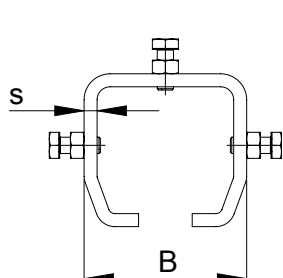
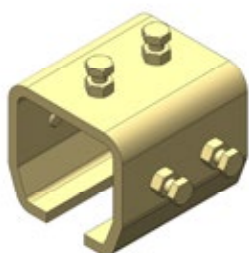

NIKO Profile No.	24.000	25.000	26.000	27.000
Part No.	24.B00P	25.B00P	26.B00P	27.B00P
L (mm)	68	90	110	120
H (mm)	54	75	94	133
B (mm)	61	81	100	116
s (mm)	4,5	6	8	10

Wall support bracket

.B01P

This kind of support is used for mounting the track directly on a wall or on other constructions with mounting bolts. CEN/TS16415:2013-D

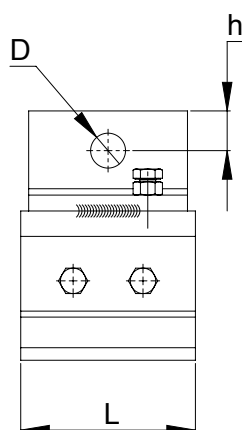
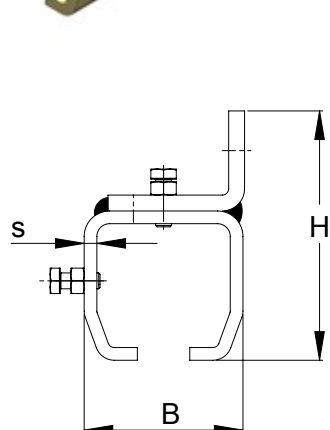
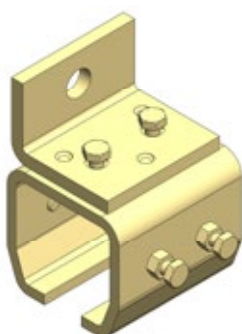

NIKO Profile No.	24.000	25.000	26.000	27.000
Part No.	24.B01P	25.B01P	26.B01P	27.B01P
L (mm)	68	90	110	120
H (mm)	95	123	156	205
B (mm)	61	81	100	116
d (mm)	8,2	-	-	-
s (mm)	4,5	6	8	10
D (mm)	13	17	22	26
h (mm)	16	18	24	27

Ceiling support bracket

.B02P

This bracket is designed for bolting direct to overhead steelwork or ceiling.
CEN/TS16415:2013-D

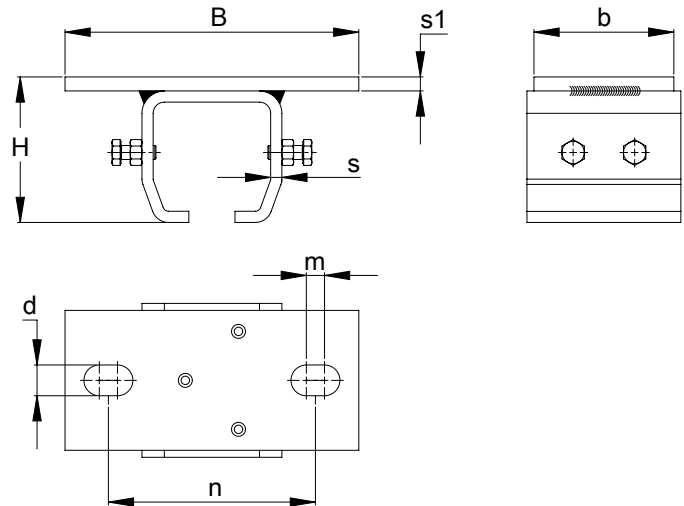
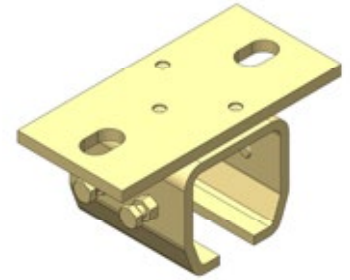

NIKO Profile No.	24.000	25.000	26.000	27.000
Part No.	24.B02P	25.B02P	26.B02P	27.B02P
B (mm)	130	171	210	260
H (mm)	60	81	104	145
b (mm)	68	80	100	120
s (mm)	4,5	25	26	27
s1 (mm)	5	6	10	12
d (mm)	13	17	22	22
n (mm)	94	124	148	178,5
m (mm)	8	10	12	23,5

Fall Arrest System

Split support bracket (CEN/TS16415 Cert.)

.B03P

.B03 is generally used for variable height configurations. CEN/TS16415:2013-D

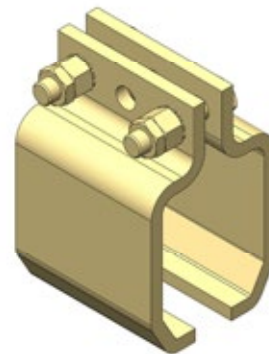
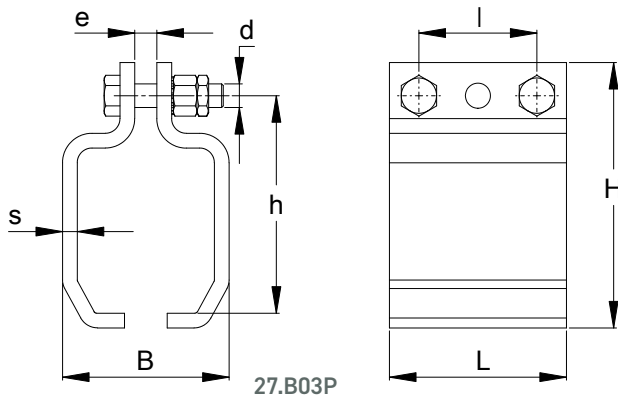

27.B03P

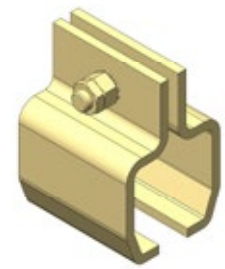

25-26.B03P

NIKO Profile No.	24.000	25.000	26.000	27.000
Part No.	24.B03P	25.B03P	26.B03P	27.B03P
B (mm)	57	77	96	110
H (mm)	88	131	150	180
h (mm)	70	94	112	148
L (mm)	50	90	110	120
s (mm)	4	6	8	10
d (mm)	M12	M16	M16	M16
e (mm)	8	10	10	15
l (mm)	-	-	-	80

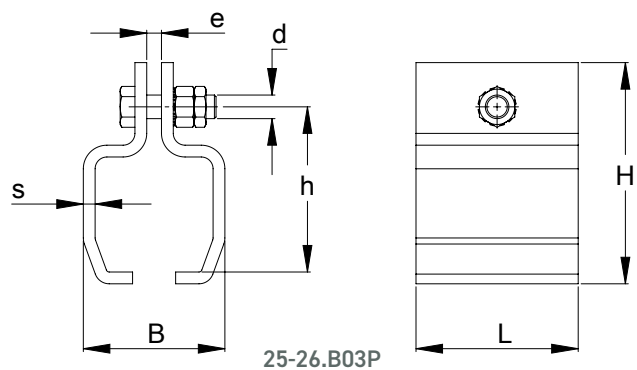

25-26.B03P

Personal Safety Systems

We reserve the right for technical amendments without obligation.
The product pictures and drawings depicted in this catalogue do not always reflect all available sizes.

Adjustable bracket with safety device

.B04P

.B04 allows the height adjustment of the rails and to correct any misalignments. CEN/TS16415:2013-D

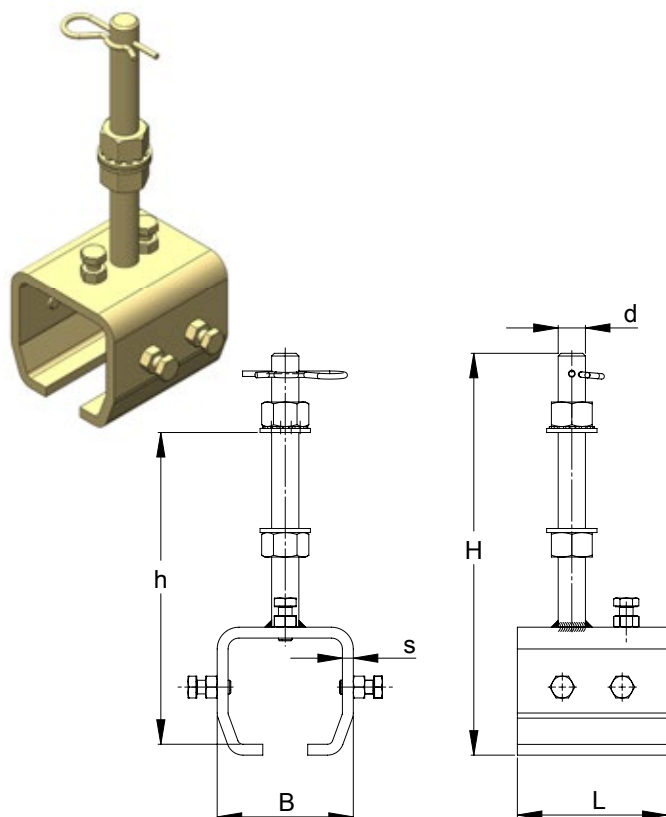

NIKO Profile No.	24.000	25.000	26.000	27.000
Part No.	24.B04P	25.B04P	26.B04P	27.B04P
B (mm)	61	81	100	116
H (mm)	146	215	295	348
h (mm)	132	170	250	295
L (mm)	68	90	110	120
s (mm)	4,5	6	8	10
d (mm)	M16	M20	M20	M30

Split suspension bracket

.B10P/.B26P

This bracket is used for mounting directly to the underside flange of a parallel I-beam. CEN/TS16415:2013-D

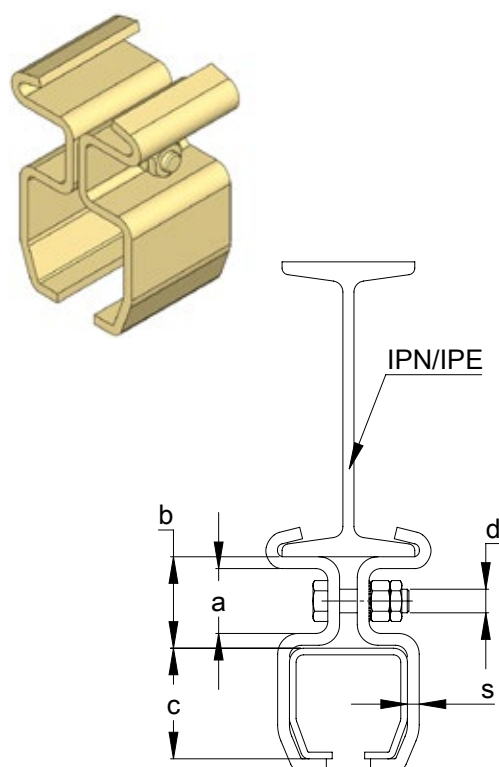

NIKO Profile No.	24.000	25.000	26.000	27.000
Dimension a in mm.	25	42	45	69
Dimension b in mm.	34	54	61	89
Dimension c in mm.	43,5	60	75	110
Dimension d in mm.	9Φ	17 Φ	17 Φ	17 Φ
s (mm)	4	6	8	10
Material	50x4	90x6	110x8	120x10
Split Suspension Bracket Joist IPN DIN 1025				
For IPN 80X42	24.B08			
for IPN 100X50	24.B10P	25.B10P		
for IPN 120X58	24.B12P	25.B12P		
for IPN 140X66	24.B14P	25.B14P		
for IPN 160X74	24.B16P	25.B16P	26.B16P	
for IPN 180X82	24.B18P	25.B18P	26.B18P	
for IPN 200X90	24.B20P	25.B20P	26.B20P	27.B20P
for IPN 200X98		25.B22P	26.B22P	27.B22P
for IPN 240X106		25.B24P	26.B24P	27.B24P
for IPN 260X113		25.B26P	26.B26P	27.B26P

Fall Arrest System

Adjustable wall bracket

.B05P

.B05 is used in combination with the .B04 adjustable bracket and it usually mounts on the wall.
CEN/TS16415:2013-D

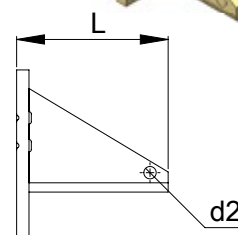
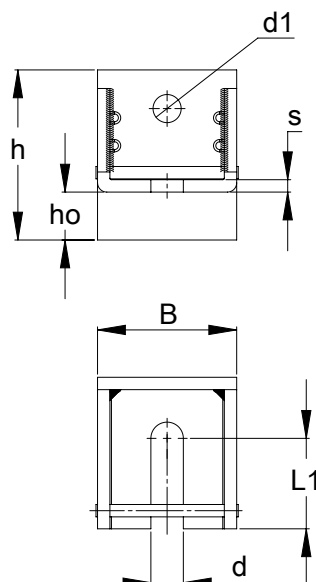

NIKO Profile No.	24.000	25/26.000
Art No.	24.B05P	26.B05P
L (mm)	60	98
B (mm)	75	90
h (mm)	80	110
ho (mm)	18	28
s (mm)	5	8
d (mm)	17	21
d1 (mm)	17	18
d2 (mm)	8	8
L1 (mm)	34	58

Double adjustable wall bracket with safety device

.B06P

Double zinc plated steel wall bracket for twin tracks, for use with bracket .B04
CEN/TS16415:2013-D

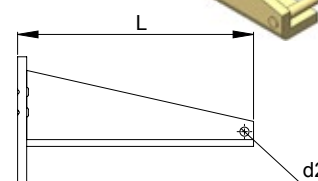
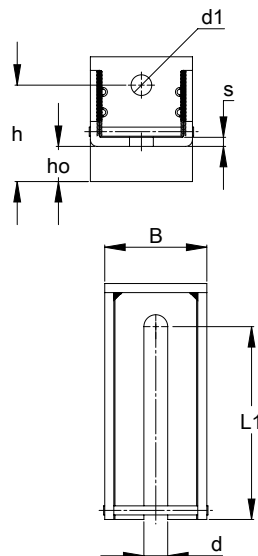
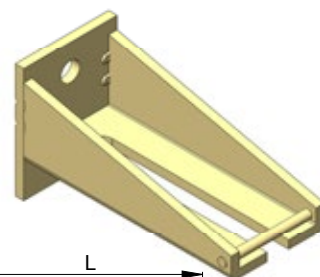

NIKO Profile No.	24.000	25.000 / 26.000	27.000
Part No.	24.B06P	26.B06P	27.B06P
L (mm)	60	208	208
B (mm)	75	90	90
h (mm)	80	84	80
ho (mm)	18	28	28
s (mm)	5	8	8
d (mm)	17	21	32
d1 (mm)	17	18	22
d2 (mm)	8	8	8
L1 (mm)	129	172	168

Personal Safety Systems

We reserve the right for technical amendments without obligation.
The product pictures and drawings depicted in this catalogue do not always reflect all available sizes.

Double joist clamp (Parallel to the I-Beam)

.B35P

This bracket is used for mounting to the underside flange of a parallel I-beam. CEN/TS16415:2013-D

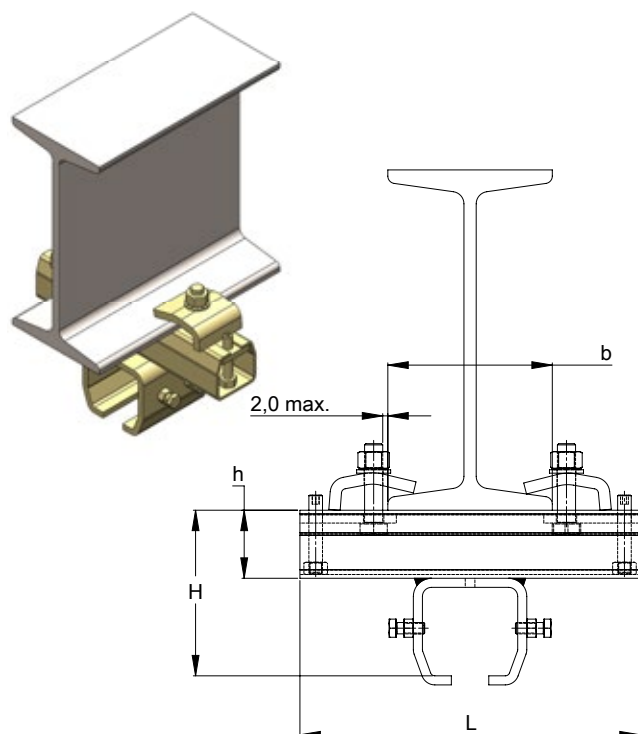

NIKO Profile No.	24.000	25.000	26.000	27.000
Part No.	24.B35P	25.B35P	26.B35P	27.B35P
L (mm)	250	300	300	330
H (mm)	94	129	146	199
h (mm)	43,5	60	60	75
b max (mm)	150	175	175	205

Adjustable joist clamp (90° to the I-Beam)

.B36P

This bracket is used for mounting to the underside flange of a vertical I-beam. CEN/TS16415:2013-D

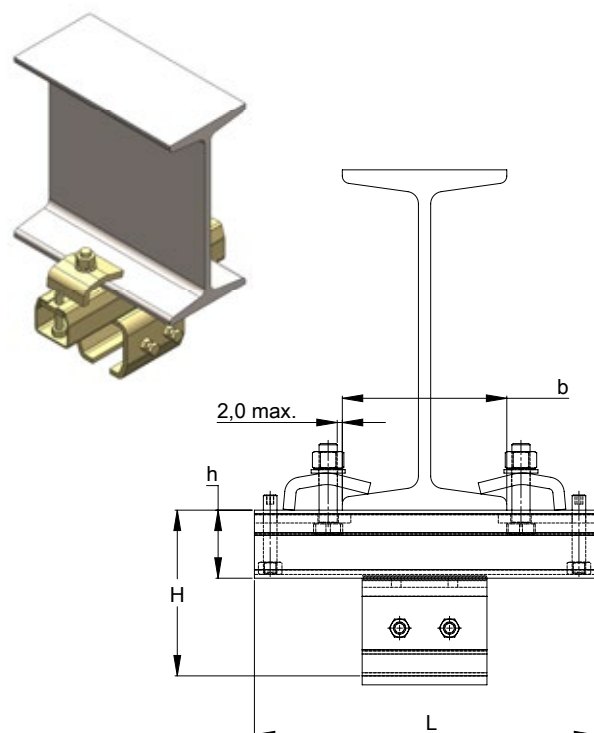

NIKO Profile No.	24.000	25.000	26.000	27.000
Part No.	24.B36P	25.B36P	26.B36P	27.B36P
L (mm)	250	300	300	330
H (mm)	94	129	146	199
h (mm)	43,5	60	60	75
b max (mm)	150	175	175	205

Adjustable joist clamp with splice joint (Parallel to I-Beam)

.B71P

This bracket is used to support and connect track profiles to the underside flange of a parallel I-beam.
CEN/TS16415:2013-D

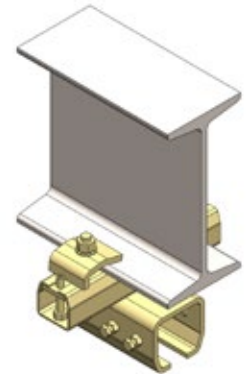
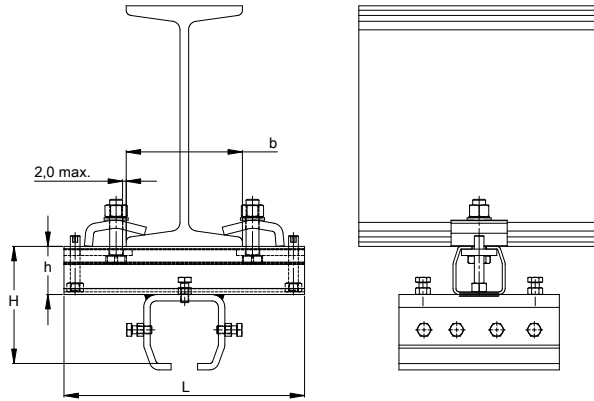

Profil Nr.	25.000	26.000	27.000
Part No.	25.B71P	26.B71P	27.B71P
L (mm)	300	300	330
H (mm)	129	146	199
h (mm)	60	60	75
b max (mm)	175	175	205

Adjustable joist clamp with splice joint (90° to the I-Beam)

.B72P

This bracket is used to support and connect track profiles to the underside flange of a vertical I-beam.
CEN/TS16415:2013-D

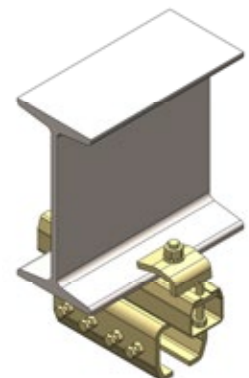
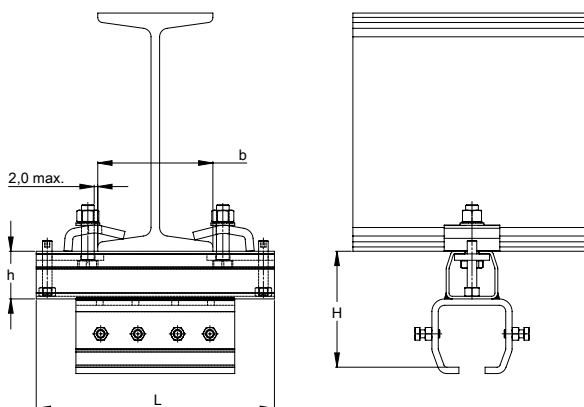

Profil Nr.	25.000	26.000	27.000
Part No.	25.B72P	26.B72P	27.B72P
L (mm)	300	300	330
H (mm)	129	146	199
h (mm)	60	60	75
b max (mm)	175	175	205

Splice joint for tracks

.B49P

The track sections are joined using the track joint by tightening the top screws first then aligning the profiles by means of the side screws. CEN/TS16415:2013-D

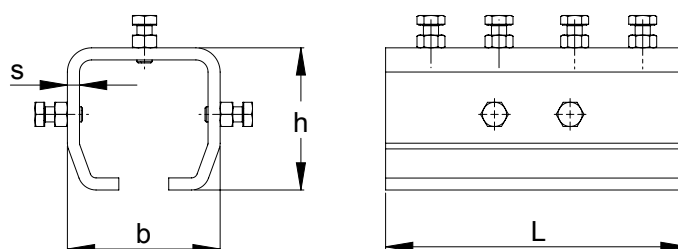
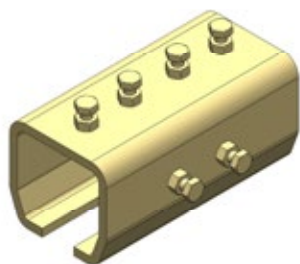

NIKO Profile No.	24.000	25.000	26.000	27.000
Part No.	24.B49P	25.B49P	26.B49P	27.B49P
L (mm)	150	180	200	250
h (mm)	54	75	94	133
b (mm)	61	81	100	116
s (mm)	4,5	6	8	10

Height adjustable support joint

.B11P

.B11 is a combination of a height adjustable bracket and a splice joint for mounting on adjustable wall brackets. CEN/TS16415:2013-D

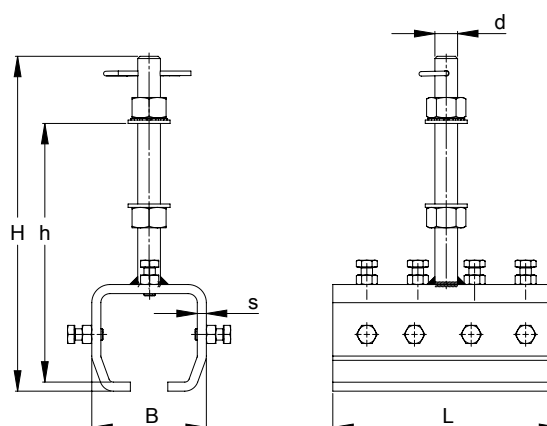
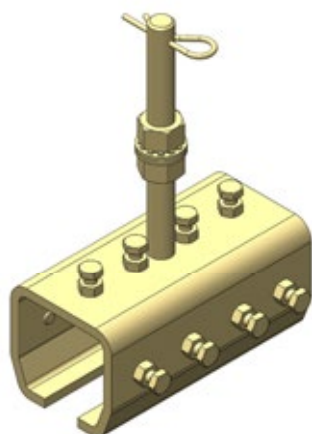

Profil Nr.	25.000	26.000	27.000
Part No.	25.B11P	26.B11P	27.B11P
B (mm)	81	100	116
H (mm)	215	295	348
h (mm)	170	250	295
L (mm)	180	200	250
s (mm)	6	8	10
d (mm)	M20	M20	M30

Ceiling support joint

.B30P

Zinc plated splice joint, for mounting direct to ceiling. Combination of a ceiling support and a splice joint.
CEN/TS16415:2013-D

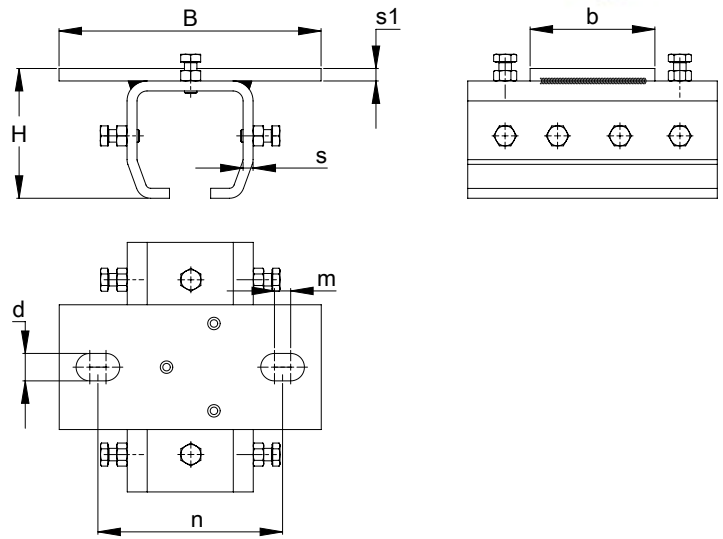
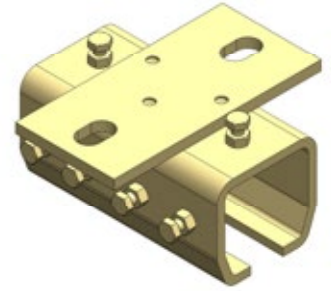

Profil Nr.	25.000	26.000	27.000
Part No.	25.B30P	26.B30P	27.B30P
B (mm)	171	210	260
H (mm)	81	104	145
b (mm)	80	100	120
s (mm)	6	8	10
d (mm)	17	22	22
n (mm)	124	148	178,5
m (mm)	10	12	23,5

Scaffolding splice joint

.B80P

This clamp is suitable for connecting and supporting the track profiles to existing scaffolding structure.
CEN/TS16415:2013-D

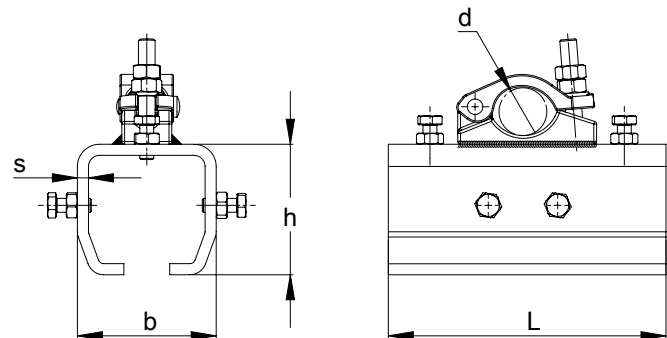
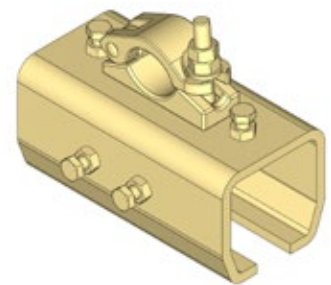

Profil Nr.	25.000	26.000	27.000
Part No.	25.B80P	26.B80P	27.B80P
L (mm)	180	200	250
h (mm)	75	94	133
b (mm)	81	100	116
s (mm)	6	8	10
d MIN (mm)	40	40	40
d MAX (mm)	48,3	48,3	48,3

Personal Safety Systems

We reserve the right for technical amendments without obligation.
The product pictures and drawings depicted in this catalogue do not always reflect all available sizes.

Scaffolding support bracket

.B81P

This clamp is suitable for supporting the track profiles to existing scaffolding structure.
CEN/TS16415:2013-D

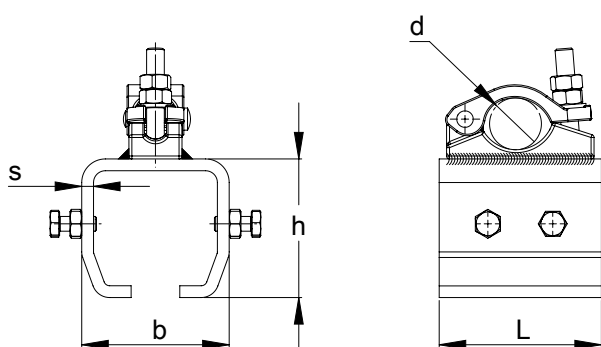
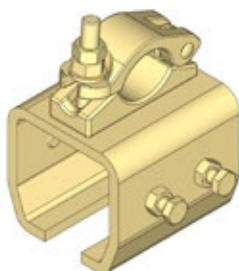

Profil Nr.	25.000	26.000	27.000
Part No.	25.B81P	26.B81P	27.B81P
L (mm)	90	110	120
h (mm)	75	94	133
b (mm)	81	100	116
s (mm)	6	8	10
d MIN (mm)	40	40	40
d MAX (mm)	48,3	48,3	48,3

Track end stop

.X01P

At the end of the open profiles, an end stop with a rubber buffer must be positioned. Used in conjunction with a fixed cross belt. CEN/TS16415:2013-D

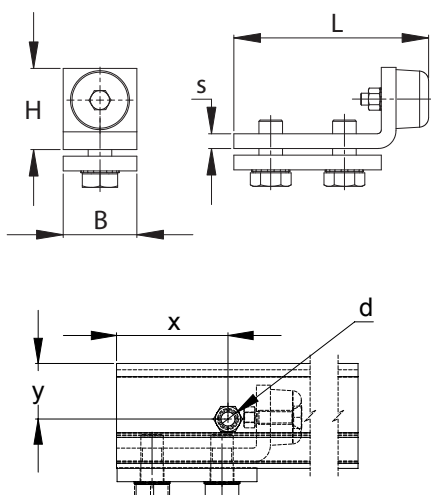
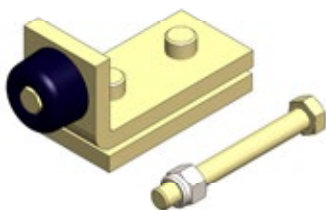

NIKO Profile No.	24.000	25.000	26.000	27.000
Part No.	24.X01P	25.X01P	26.X01P	27.X01P
L (mm)	75	120	130	130
H (mm)	30	47	60	60
B (mm)	30	40	50	50
s (mm)	4	8	10	10
x (mm)	60	85	85	85
y (mm)	20	30	30	60
d (screw dimensions in mm)	M8X60	M8X80	M12X100	M16X120
Hole diameter for screw (mm)	8,5	8,5	13	17

Personal Safety Systems

We reserve the right for technical amendments without obligation.
The product pictures and drawings depicted in this catalogue do not always reflect all available sizes.

4-Wheel trolley with hole

.T10P

This trolley is ideal for non standard self built applications. EN 795:2012-D CERT

NIKO Profile No.	24.000	25.000	26.000	27.000
Part No.	24.T10P	25.T10P	26.T10P	27.T10P
L (mm)	100	120	145	210
H (mm)	54	62	70	180
h (mm)	43,5	60	75	110
b (mm)	48,5	65	80	90
D (mm)	14	18	22	26
e (mm)	15	20	24	35
d1 (mm)	10	12	17	20

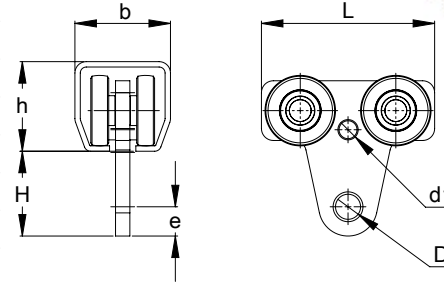

4-Wheel trolley with a rotating eye nut DIN 582

.T40P

4-wheel trolleys are suitable for hanging safety belts for fall arrest. EN 795:2012-D CERT

NIKO Profile No.	24.000	25.000	26.000	27.000
Part No.	24.T40P	25.T40P	26.T40P	27.T40P
L (mm)	90	110	150	200
H (mm)	82	93	123	163
h (mm)	43,5	60	75	110
b (mm)	48,5	65	80	90
D (mm)	63	72	90	108
d (mm)	10	12	17	20
d1 (mm)	35	40	50	60

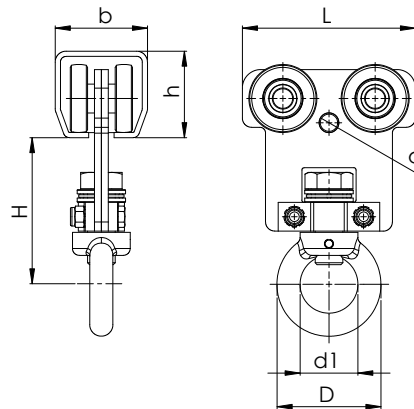

End carriage with track joint

.T54P

This end carriage trolley with horizontal bearings are used to connecting the bridge crane to the long travel tracks in a fall arrest crane system. EN/795:2012-D

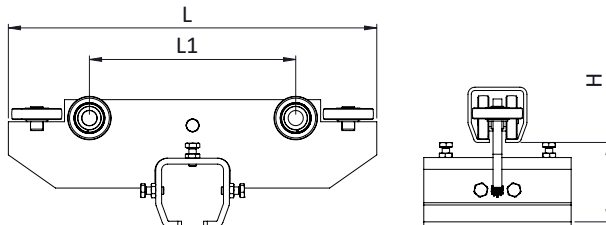

NIKO Profile No.	25.000	26.000	27.000
Part No.	25.T54P	26.T54P	27.T45P
L (mm)	450	500	600
L1 (mm)	276	280	340
H (mm)	91	106	163

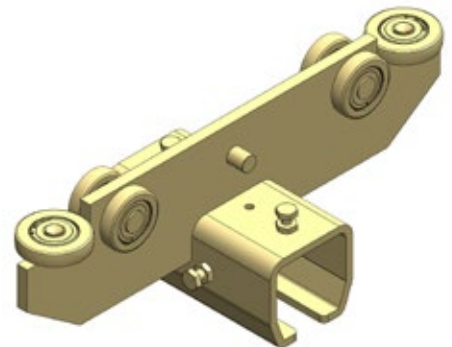

ZERTIFIKAT | CERTIFICATE | CERTIFICADO | CERTIFIKAT | شهادة | 证书 | 인증서

Fall Arrest System



Baumusterprüfbescheinigung Certificate



Nr.: 1911-1911-PSA19-081-Z

Hersteller: <i>Manufacturer:</i>	NIKO Vertriebs GmbH Hainfelder Straße 48 A – 2560 Berndorf	Original-hersteller: <i>OEM:</i>	Helm Hellas S.A. P.O. Box 209 GR – 20100 Korinthos
Produkt: <i>Product:</i>	Persönliche Absturzschutzausrüstung – Anschlagleinrichtungen Typ D <i>Personal fall protection equipment – Anchor devices type D</i>		
Typ: <i>Type:</i>	NIKO PSS 25-26-27 <i>NIKO PSS 25-26-27</i>		
Beschreibungen: <i>Description:</i>	Zulässige Varianten, Komponenten – Siehe Anhang <i>Valid types, components – see annex</i>		
Prüfgrundlagen: <i>Tested according to:</i>	ÖNORM EN 795:2012 (ident EN 795:2012) CEN/TS 16415:2013 ÖNORM EN 365:2004 (ident EN 365:2004)		
Bemerkungen: <i>Remarks:</i>	Siehe Anhang <i>See annex</i>		

Hiermit bestätigt die TÜV AUSTRIA SERVICES GMBH, dass das oben angeführte Produkt den grundlegenden Sicherheits-Anforderungen entspricht. Grundlage dieses Zertifikates ist das zur Prüfung und Zertifizierung vorgelegte Prüfmuster und die technische Dokumentation.
Hereby TÜV AUSTRIA SERVICES GMBH confirms that the above-mentioned product meets the essential safety requirements. The certificate is based on the test specimen and the technical documentation subjected to the test and the certification.

TÜV-A-MHF/FT-14/FT04-026
 Vorgängerdokument / former document
10.11.2014
 Datum / date

01.11.2019
Datum
date

Dipl.-Ing. Georg Sonntag
Geprüft
examined



Ing. Georg Gottschlich
Freigegeben
released

31.10.2024
Gültig bis
valid till

TÜV AUSTRIA SERVICES GMBH
Deutschstraße 10
A-1230 Wien
FM-INE-PSA-Z-0100a /Rev.03



Veröffentlichung nur mit Erlaubnis des TÜV AUSTRIA. The reproduction of this document is subject to the approval by TÜV AUSTRIA.

Our quality control department is manned by experienced and highly skilled engineers. Our test lab is equipped with endurance test stands, tensile stress equipment, hardness test machines and other laboratory equipment. Virtual stress analysis is also performed during the developing phase of every component.

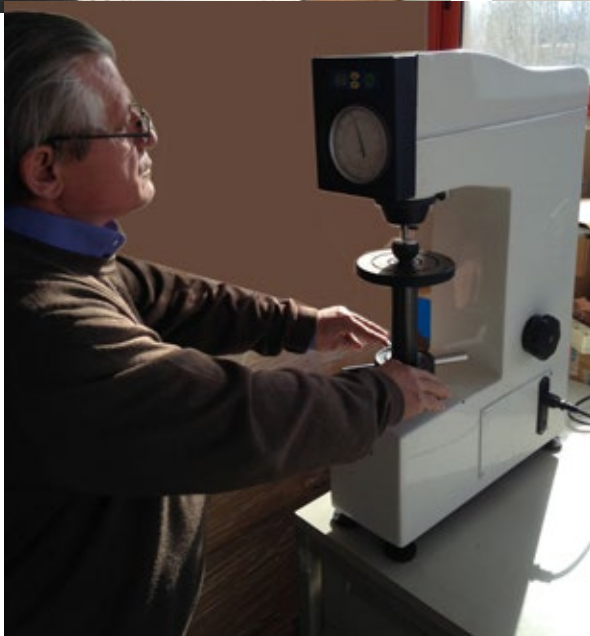
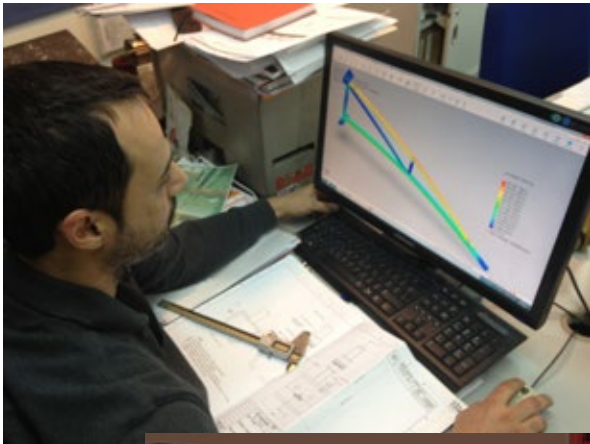

Fall Arrest System



Personal Safety Systems

We reserve the right for technical amendments without obligation. The product pictures and drawings depicted in this catalogue do not always reflect all available sizes.



AUSTRIA-
NIKO Vertriebs GmbH
 Hainfelder Straße 48
 A - 2560 Berndorf
 Tel. 0043 (0) 2672 21201
 Fax 0043 (0) 2672-21201-13
 office.at@niko.eu.com
www.niko.world

POLAND-
NIKO Polska
 Skrzynno 192a
 Ostrowek 98-311
 Tel. +48 504 003 556
 info.pl@niko.eu.com
www.niko.world

GREECE-
Helm Hellas S.A.
 82nd Km Athens-Korinthos
 P.O. Box 209
 GR - 201 00 KORINTHOS
 Tel. 0030 27410 76800
 Fax 0030 27410 25368
 info@niko.eu.com
www.niko.eu.com

NIKO Conveyors
 597 Middle Street
 Bristol, CT 06010
 Tel. 001 860-845-8179
 info@NIKOconveyors.com
www.nikoconveyors.com

NikoTrack/NIKO US
 9 Stockholm St
 Newport, RI 02840
 C: 401-835-8640
 Alex.Koza@niko.eu.com
 info@nikotrack.com
www.nikotrack.com

CANADA -
NIKO Crane Canada
 615, rue du Nickel
 Québec (Québec) G2N 0J9
 Tel. 418 841.2287
 info@smakdesign.ca
www.smakmanutention.com

UNITED KINGDOM-
NIKO Ltd
 Airfield Park Business Park
 Welsh Road East, Southam
 Warwickshire, CV47 1NE
 Tel. 0044 (0) 1926 813111
 Fax 0044 (0) 1926 815599
 Sales@niko.co.uk
www.niko.co.uk

USA Light Crane Systems-
NIKORAIL
 8000 Joliet Rd.
 McCook, IL 60525
 Toll Free 888.352.1213
 Tel. 001 708-352-1213
 sales@hsicrane.com
www.nikorail.com

GERMANY-
NIKO Technik GmbH
 Robert-Bosch-Str. 14
 DE - 42489 Wülfrath
 Tel. 0049 (0) 2058 9093603
 Fax 0049 (0) 2058 9093604
 office.de@niko.eu.com
www.niko.world

CHINA-
NIKO TRADING (SHANGHAI) Co., Ltd
 Room 901-156, No.18
 Tianshan Road, Changning District,
 P.R.China - 201802 Shanghai
 Tel. 0086 134 2785 9785
 info.cn@niko.eu.com

www.niko.eu.com

Your **NIKO** agent will be happy to advise you:



Complete product range **NIKO**:

- Light duty sliding door hardware
- Heavy duty sliding door hardware
- Conveyor systems
- Light cranes
- Cable trolleys, festoon systems & conductor bars
- Personal fall arrest systems (EN 795)
- Accessories for gates and doors